

Disassembly of Waste Electrical and Electronic Equipment (WEEE) Manual

EU Waste Electronic and Electrical Equipment Directive require producers to provide information of the different electronic and electrical materials and components found in their products at its end-of-life, and disassembly references to treatment and recycling facilities.

This document communicates, according to the best of Lexmark’s knowledge, the following information that is intended only for the use of treatment and recycling facilities:

1. Product information
2. Materials and components list for selective treatment
3. Disassembly tools
4. Disassembly references

1. Product information

Model name(s)—Indicate all model name(s) within the product family

Model name
Lexmark C950de

** Add rows as needed*

2. Materials and components list for selective treatment

Items	Quantity	Notes
Polychlorinated biphenyls (PCB) containing capacitors	0	N/A
Mercury containing components, such as switches or backlighting lamps	0	N/A
Batteries	1	Lithium Manganese Dioxide coin cell
Printed circuit boards greater than 10 cm ²	10	
Toner cartridges, liquid and pasty, as well as colour toner	5	4 Toner cartridges and 1 Waste toner bottle
Plastic containing brominated flame retardants	0	N/A
Asbestos waste and components which contain asbestos	0	N/A
Cathode ray tubes	0	N/A
Chlorofluorocarbons (CFC), Hydrochlorofluorocarbons (HCFC) or Hydrofluorocarbons (HFC), Hydrocarbons (HC)	0	N/A

Gas discharge lamps	0	N/A
Liquid Crystal Display (LCD) greater than 100 cm ² and those back-lighted with Gas discharge lamps	1	N/A
External electrical cables	1	Power cable – Rear side of the device
Components containing refractory fibres	0	N/A
Components containing radioactive substances	0	N/A
Electrolyte capacitors containing substances of concern ¹	0	N/A

¹ With (height > 25 mm, diameter > 25 mm or proportionately similar volume)

3. Disassembly tools

Item
#2 Phillips screwdriver, magnetic
Wire cutter
E-clip puller or a small flat-head screwdriver

4. Disassembly references

4.1. Removal Procedures



C950de WEEE removal

WEEE materials and components removal procedures are available upon request.

Contact: recycling@lexmark.com

4.2. Graphical illustration of material's and component's location

See next page

**C950
Location**

Operator Panel (SFP)

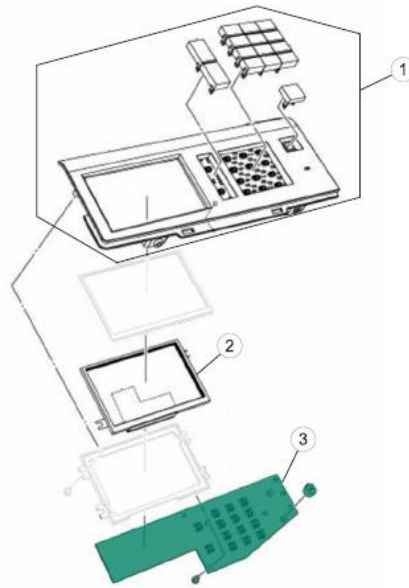

Index	Description
1	SFP operator panel top cover
2	SFP touch screen
3	SFP operator panel PCBA

High Capacity Feed (HCF)

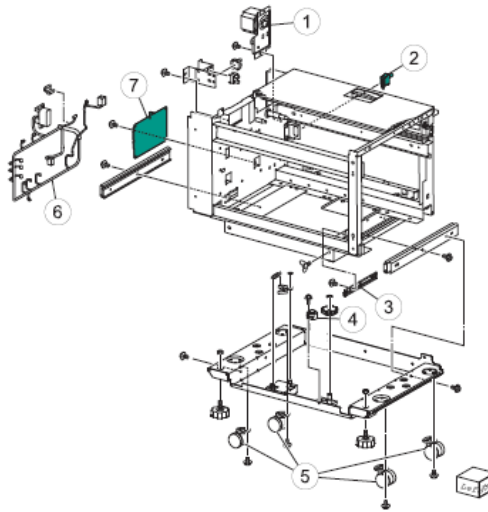

Index	Description
1	HCF transport motor
2	Sensor (HCF unit docking interlock)
3	HCF rack gear
4	HCF sliding damper
5	HCF caster
6	HCF main cable
7	HCF controller card PCBA

**C950
Location**

Electrical 2

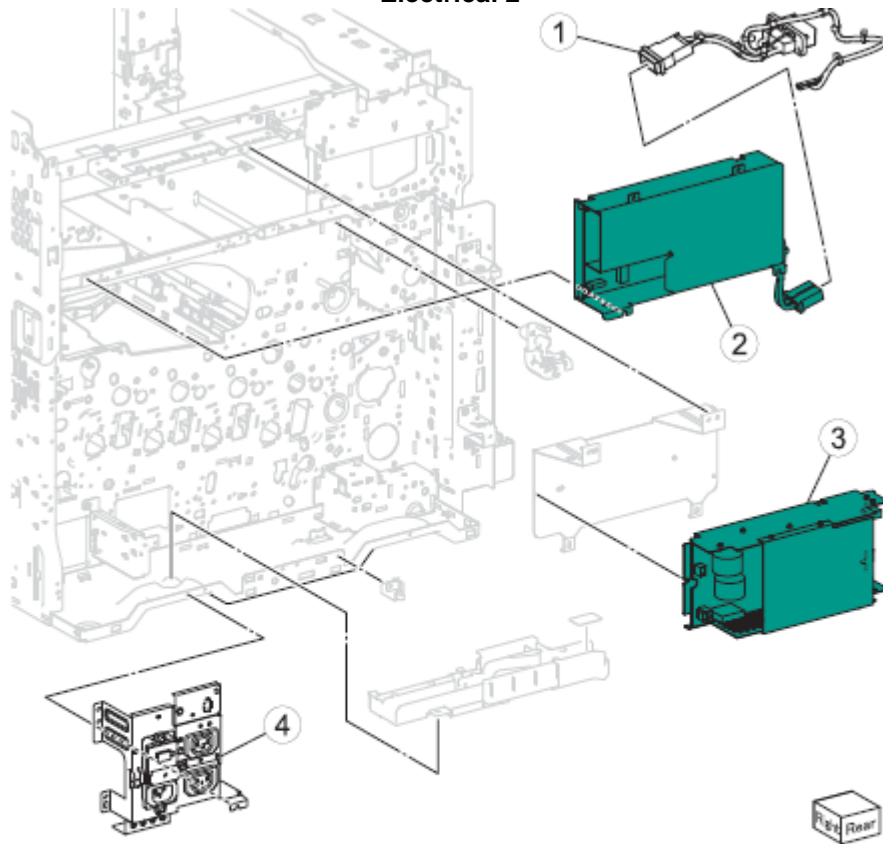

Index	Description
1	Fuser power contact 110V
1	Fuser power contact 220V
2	Fuser driver PCBA 110V
2	Fuser driver PCBA 220V
3	Sub LVPS PCBA
4	Main power GFI interface 110V
4	Main power GFI interface 220V

**C950
Location**

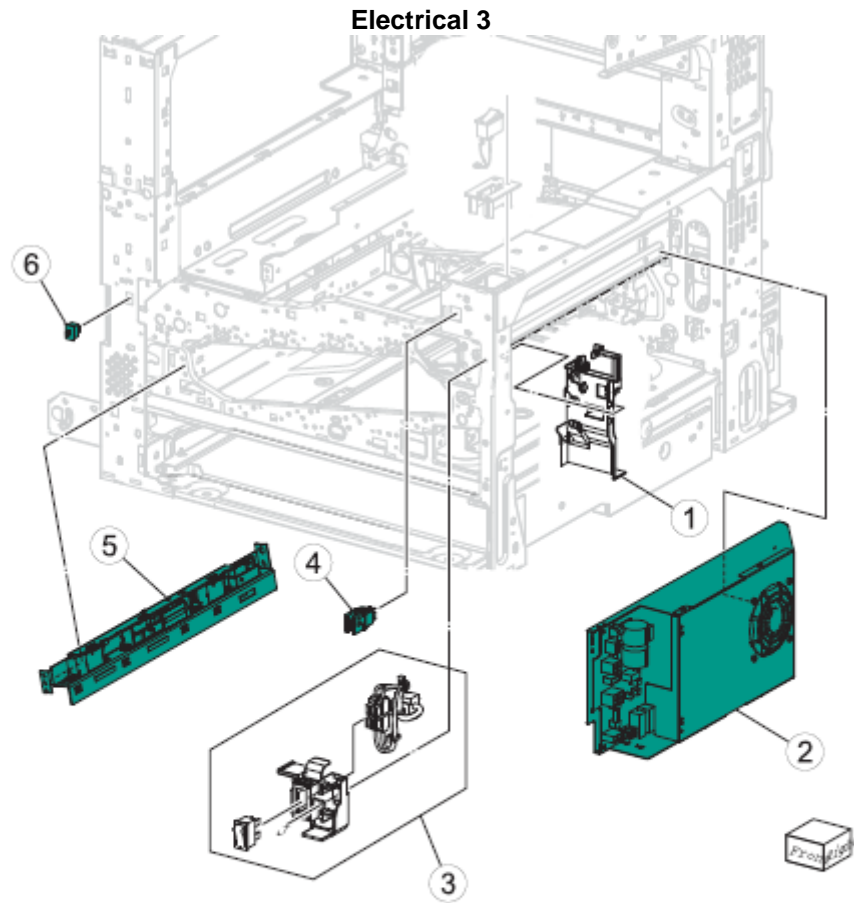

Index	Description
1	LVPS front fan guide
2	LVPS PCBA
3	Main power switch
4	Sensor (printer right front door interlock)
5	Sensor (Image calibration)
6	Front door sensor

**C950
Location**

Electrical 4

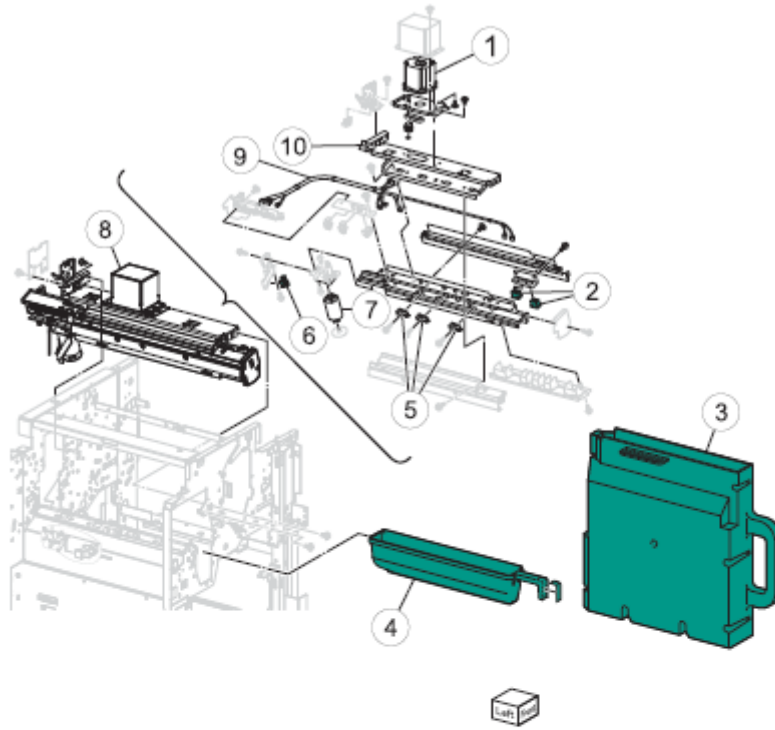

Index	Description
1	Punch carriage shift motor
2	Sensor (punch unit side reg 1)
2	Sensor (punch unit side reg 2)
3	Punch waste box
4	Punch waste box bottle
5	Punch unit stopper
6	Sensor (punch unit motor encoder)
7	Punch unit motor
8	3-hole punch unit assembly
8	2-hole punch unit assembly
8	4-hole punch unit assembly
9	2/3 punch hammer sub-assembly
9	2/4 punch hammer sub-assembly
10	Punch unit main cable
11	Punch carriage

**C950
Location**

Developer 2

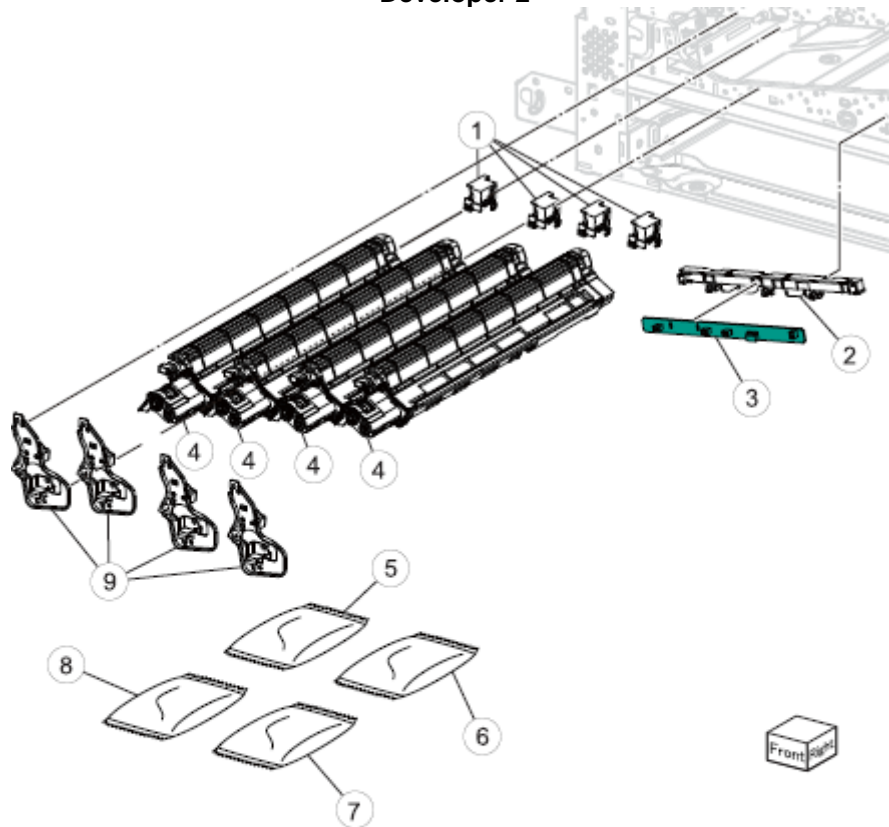

Index	Description
1	Developer housing rear plunger
2	ATC sensor PCB bracket
3	ATC sensor PCB
4	Developer housing
5	K developer carrier
6	C developer carrier
7	Y developer carrier
8	M developer carrier
9	Developer bracket

**C950
Location**

HVPS

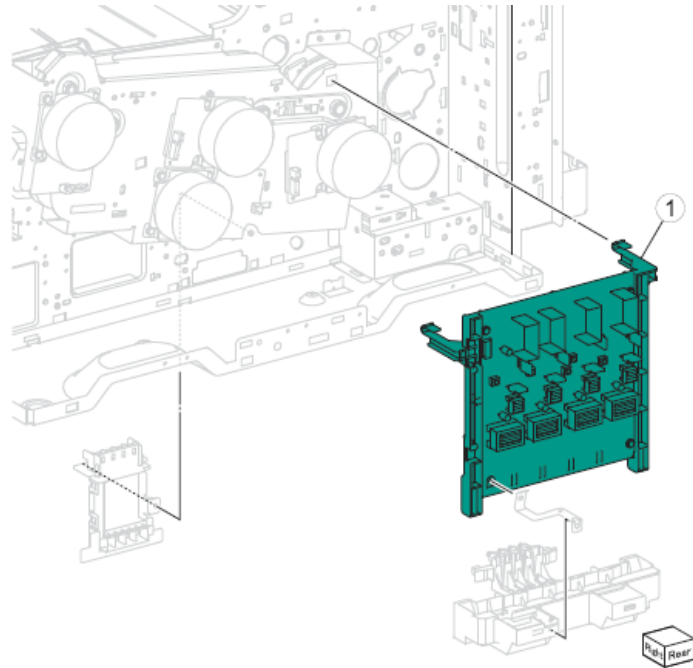

Index	Description
1	Developer HVPS PCBA

Transfer belt 2

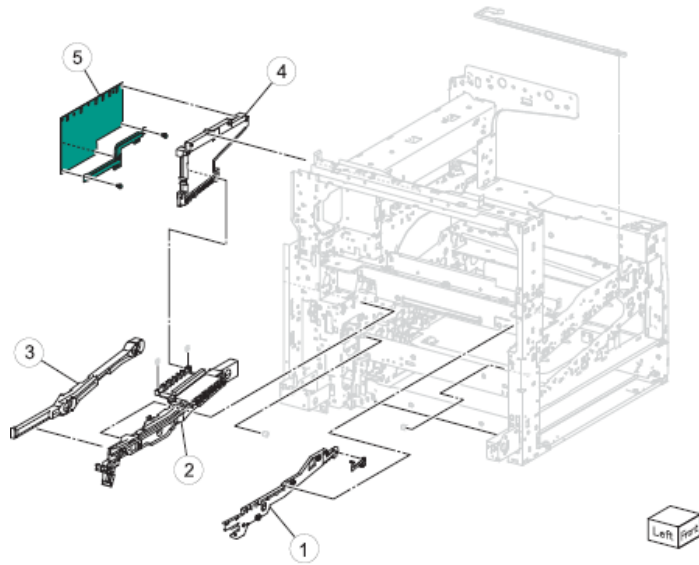

Index	Description
1	Front transfer belt guide
2	Rear transfer belt guide
3	Belt removal actuator
4	1st transfer conductor housing
5	Transfer roll HVPS PCBA

C950 Location

Media Feed 1

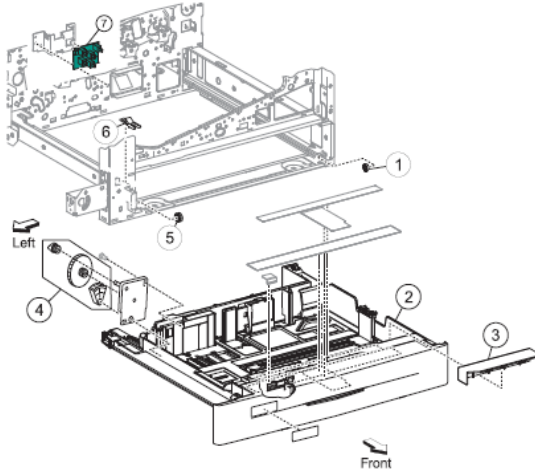

Index	Description
1	Media tray right roller
2	Printer media tray # 1
3	Media tray compartment cover
4	Media tray lift gear kit includes: <ul style="list-style-type: none"> • Tray lift coupling gear 13T • Tray lift gear 13/60T • Tray lift sector gear 12T
5	Media tray left roller
6	Media tray stop
7	Media size switch PCB

Tray Module Transport 1

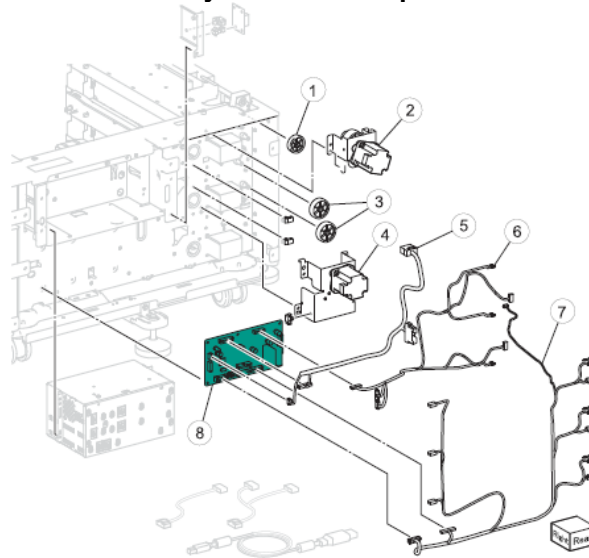

Index	Description
1	STM 34T gear
2	1TM/STM upper transport motor
3	STM/TTM 39T gear
4	Tray module lower transport motor
5	STM interface cable
6	STM motor cable
7	STM sensor cable
8	Tray module controller PCBA

**C950
Location**

rive 2

Drive 2

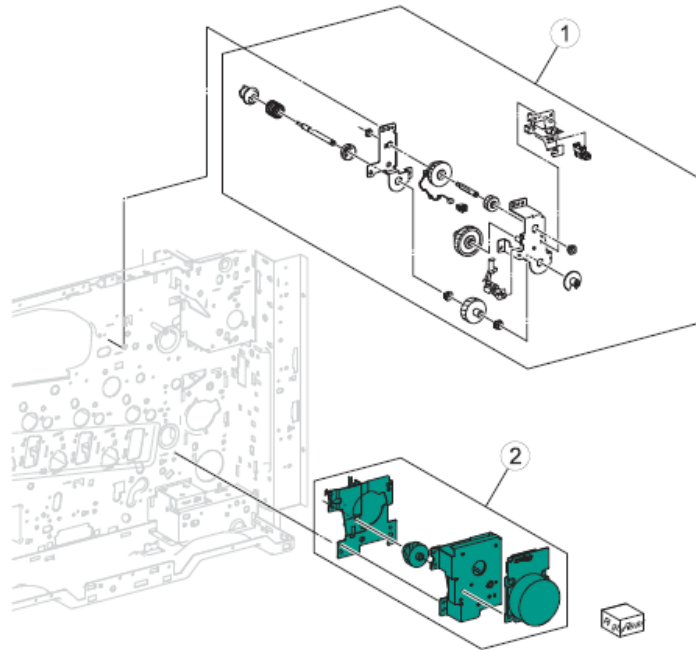

Index	Description
1	1st transfer retract clutch assembly
2	Registration drive motor

Drive 3

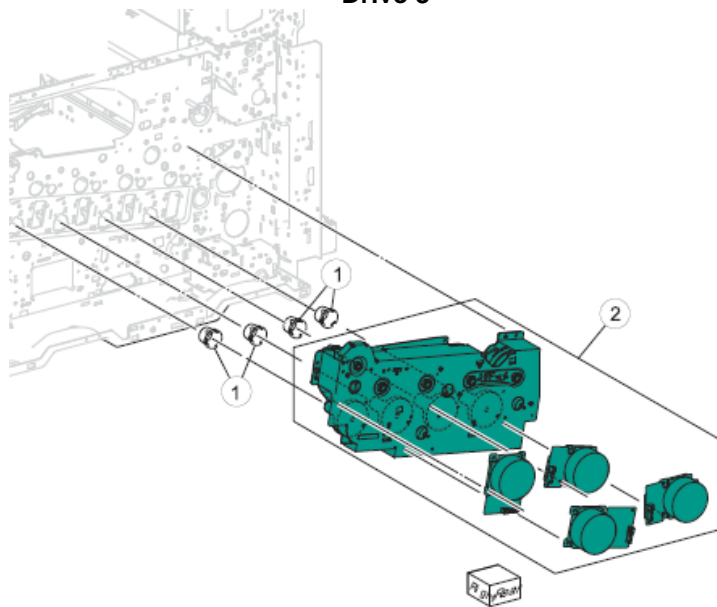

Index	Description
1	Coupler
2	PC/developer drive motor assembly

C950
Location
Electrical 1

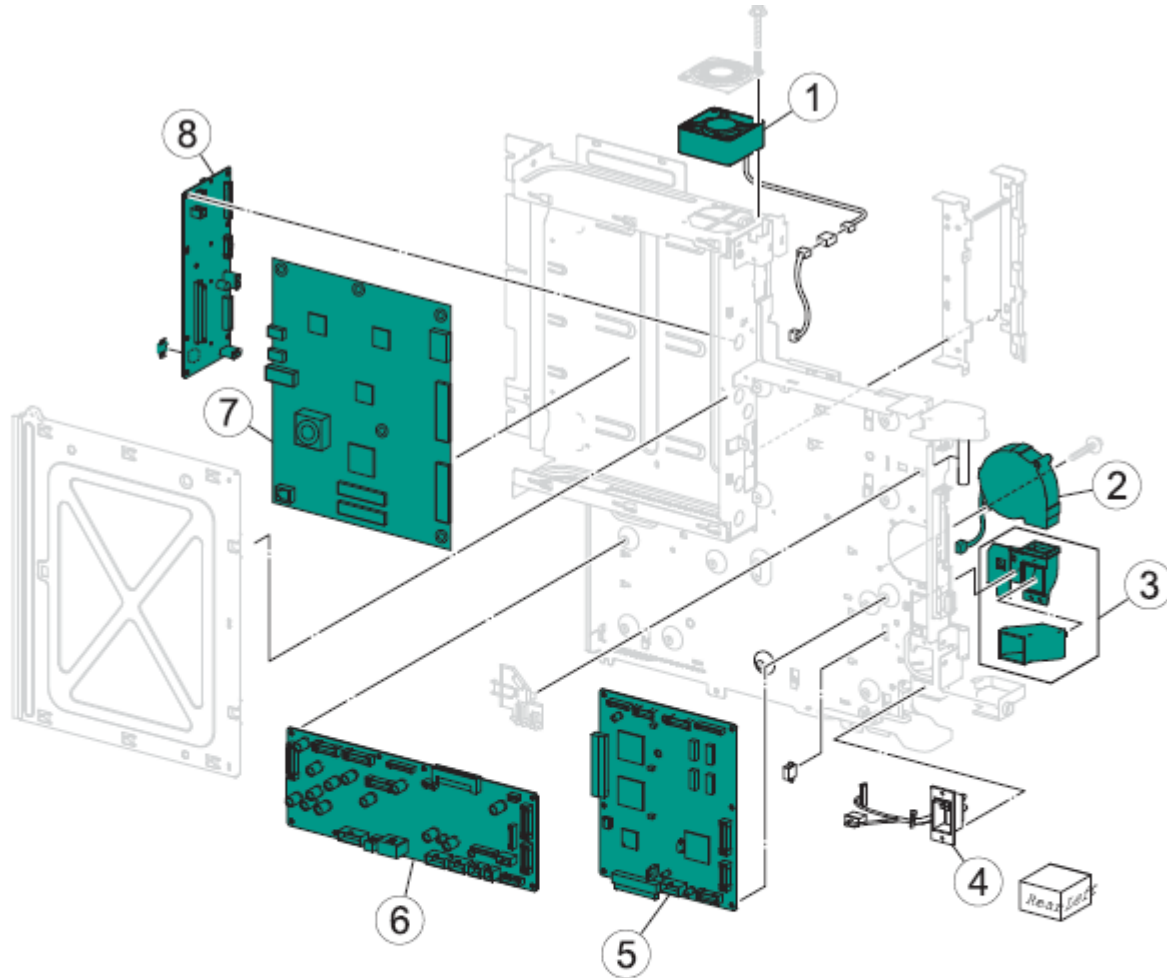

Index	Description
1	Controller cooling fan
2	Suction fan
3	Suction fan duct
4	HCF interface contact
5	Upper printer engine PCBA
6	Lower engine PCBA
7	RIP PCBA (SFP)
8	Bridge PCBA (SFP)

**C950
Location**

Location of Sensors, Fans, Motors and Input and Output Options PCB, Sensors can be found in the C95x WEEE Removal